

zero 2000B

Garrard

introduction

Index

Page 2	Introduction
Page 3	Packing list Setting up
Page 4	Fitting the cartridge
Page 7	Connecting the leads
Page 8	Operation
Page 11	The automatic record counter Setting up (continued)
Page 12	Attaching leads
Page 13	BHC 20 base and cover †(see 'Optional extras')
Page 14	Routine maintenance
Page 15	Adjustments
Page 16	Service hints
Page 17	Service and spares

The Garrard Z2000B

This is a superb two-speed belt-driven transcription turntable with facilities for automatic use. It is a worthy addition to the long line of record playing equipment from a company with over half a century of experience and a world-wide reputation for design and quality.

You will appreciate such refinements as

- a record pitch control and illuminated stroboscopic markings
- a counterbalanced pickup arm of negligible tracking error with a slide-in cartridge carrier and jewelled cross-pivots.
- an automatic record counter to help assess stylus wear
- a long stylus force scale for a high degree of accuracy
- damped lowering of the pickup arm. To help pinpoint its landing position the descent of the arm can be held at any position while cueing. When lifting the arm under manual control its movement is also damped
- suitability for use with QS, SQ and CD-4 and other quadrasonic as well as stereophonic equipment (with appropriate cartridge)
- a pickup arm bias compensator calibrated for elliptical, conical and Shibata stylus tip profiles
- a cartridge tilting device with settings for single-record and multi-record play
- a heavy non-magnetic turntable
- a synchronous motor with the torque of an induction motor

In addition to manual operation it will automatically play single 7 inch (17cm), 45 rev/min records, 10 inch (25cm) and 12 inch (30cm), 33½ rev/min records. It will also play a stack up to six

12 inch, 33½ rev/min records, dependent on record thickness and cartridge depth.

The Garrard Z2000B automatic transcription turntable is available in two versions

- 1 The Module. This is the Z2000B deck assembled to a base, complete with dust cover and connecting leads. A pickup cartridge is fitted when specified by the distributor.
- 2 The Deck. This is the same mechanism ready for installation by the owner into the housing of his choice. Connecting leads and a pickup cartridge are fitted when specified by the distributor.

Depending on the 4-pole synchronous motor and pulley fitted the unit is suitable for use with one of the following power supplies

- 1 220/240V, 50Hz
- 2 110/125V, 60Hz
- 3 115/230V, 50/60Hz

Performance

Rumble: DIN A: -40dB. DIN B: -60dB. (DIN 45539)

Wow and Flutter: 0.12% r.m.s. (DIN 45507)

Speed control: 33½ and 45 rev/min ± approximately 3%

Power consumption: Approximately 9 watts

For best results

Naturally you are keen to put your new turntable into use as soon as possible. However, as you have already realised, it is a precision instrument and should be treated as such. For this reason we strongly advise you to read the instructions and become familiar with the unit before installing or operating it. You will then obtain the full benefit of its capabilities.

Terminology

Different territories have their own names for particular parts of a unit. Hence - a turntable (the rotating component) may be known as a platter, a pickup arm as a tone arm, a pickup arm bias compensator as an anti-skating device and an intermediate wheel as an idler wheel. When terminology is agreed internationally then we shall, of course, use it.

Optional extras

See page 17.

†The BHC 20 is not obtainable in North America. A special base and cover is available in this territory.

WARNING. To prevent fire or shock hazard do not expose this appliance to rain or moisture.

packing list

After unpacking the equipment, other items will be found in the carton in addition to the unit. Several of these are in one of the polystyrene foam packing pieces. The following items are provided:

1 Short spindle for playing single records

Fit this in the centre of the turntable and press it down into place. It revolves with the turntable to minimise wear of the record centre hole, and is removed by a straight upward pull.

2 Long record spindle for playing a stack of records

Fit and remove this in a similar way to the short spindle, except that it must also be turned until it is held in a D-slot during insertion. It is also held in place by the turntable retaining clip.

3 Large centre-hole record adaptor

Fit this over the short spindle when playing records with 1½ inch (38mm) centre holes.

4 Cartridge fitting parts

These include a selection of fixing screws, a cartridge tilt wedge with fitting instructions and a clear plastic setting gauge. Unnecessary parts will not be provided when a cartridge is factory-fitted.

5 Pickup arm counterbalance weight

Wind this onto the rear of the arm, chamfer to the front, in a clockwise direction. It must be fitted and removed only by a winding action. Pushing or pulling could damage its isolating member.

6 Lubricating Oil

Smear a little over its spindle before fitting the turntable.

7 Drive belt

8 Turntable retaining clip (shown fitted to spindle)

Note its position on the spindle, slide it off and put it aside ready for use.

9 Turntable (not shown)

Fit the drive belt around the inner drum of the turntable and hold it under tension with the left thumb through the top of one of the two large holes. Slide the turntable onto its spindle in the centre of the well in the unit plate. Rotate it slightly until the belt can be passed around the V-pulley on top of the rubber intermediate wheel and through the gap in the belt guide. Refit the retaining clip, see diagram on page 14.

10 Turntable mat (not shown)

This is centralised on the turntable and pressed down lightly at the centre to position it. The centre disc is held down in its recess by three small lugs in the rubber mat.

Garrard protects your unit right into the home. Please remove protective film from trim plates. If a residue of adhesive is present on the top surface remove by the use of a damped cloth before connecting the unit to a power supply.

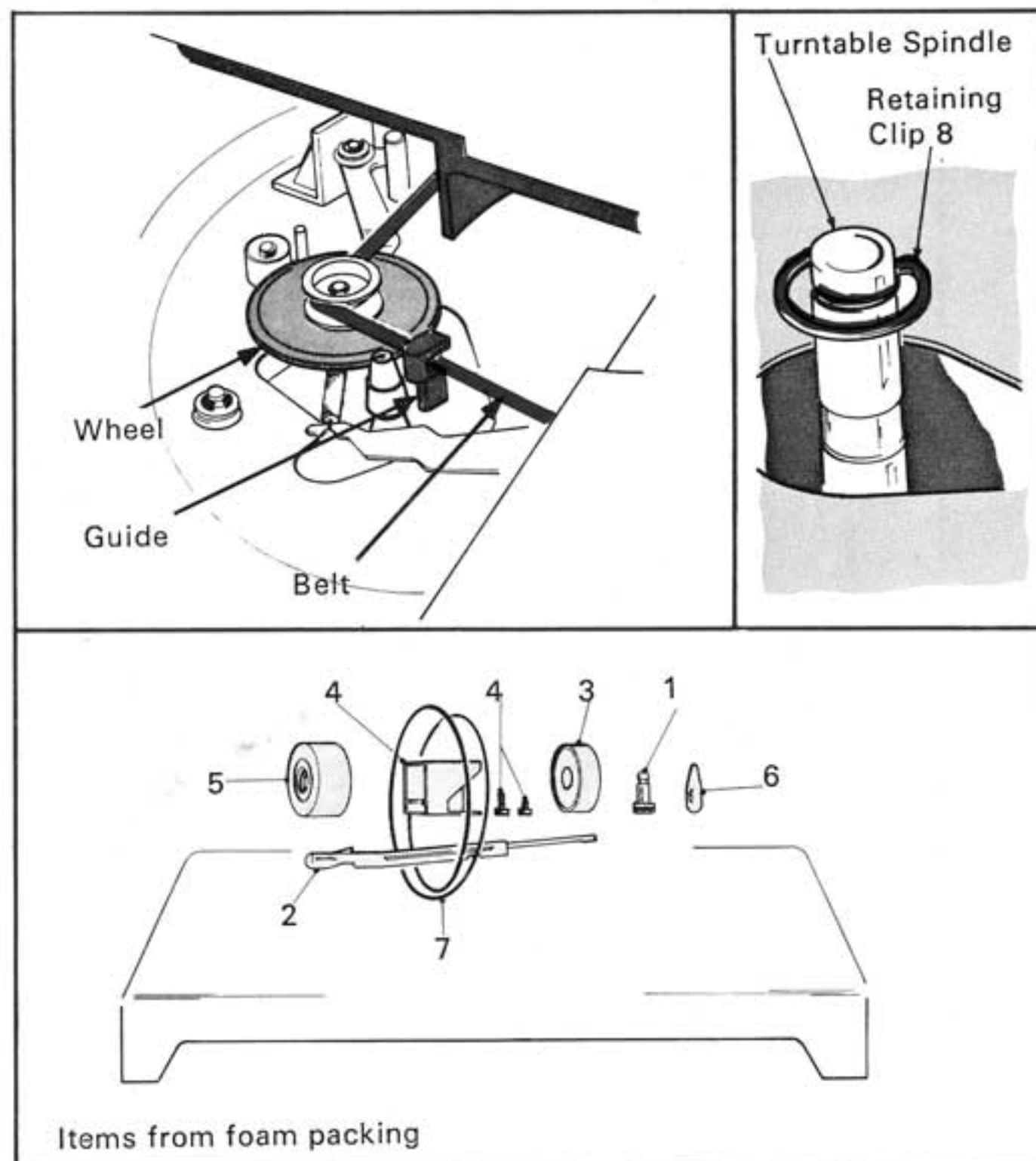

setting up

Fitting the pickup cartridge

The fixing screws and cartridge setting gauge provided enable a wide range of high quality cartridges to be fitted correctly. The cartridge must have standard $\frac{1}{2}$ inch fixing screw centres.

Fit the cartridge as outlined below:

- A Remove the cartridge carrier from the pickup arm
- B Attach the cartridge to the carrier
- C Align the cartridge
- D Connect leads to the cartridge
- E Refit the carrier
- F Set stylus force
- G Set the pickup arm bias compensator

A To remove the cartridge carrier

Move the pickup arm locking lever to 'free'. Support the pickup arm over the turntable with one hand to avoid strain and withdraw the carrier with the other hand. Turn the carrier over and peel off any adhesive tape used to hold the coloured leads during transit. When removing the carrier with a cartridge fitted, support the arm well clear of the operating controls to avoid risk of damage to the cartridge.

B To attach the cartridge

- 1 Secure the cartridge to the carrier by passing a pair of screws through the cartridge mounting. Fit them into the threaded holes in the sliding locking plate. The screws must not protrude through the far side of the plate.
- 2 Tighten the screws just sufficiently to hold the cartridge in place. These screws have British Association No. 6 (6BA) threads and are supplied in a set of pairs of various lengths. Together with the fixing screws normally provided with a pickup cartridge, they enable almost any cartridge with standard $\frac{1}{2}$ inch centres to be fitted.

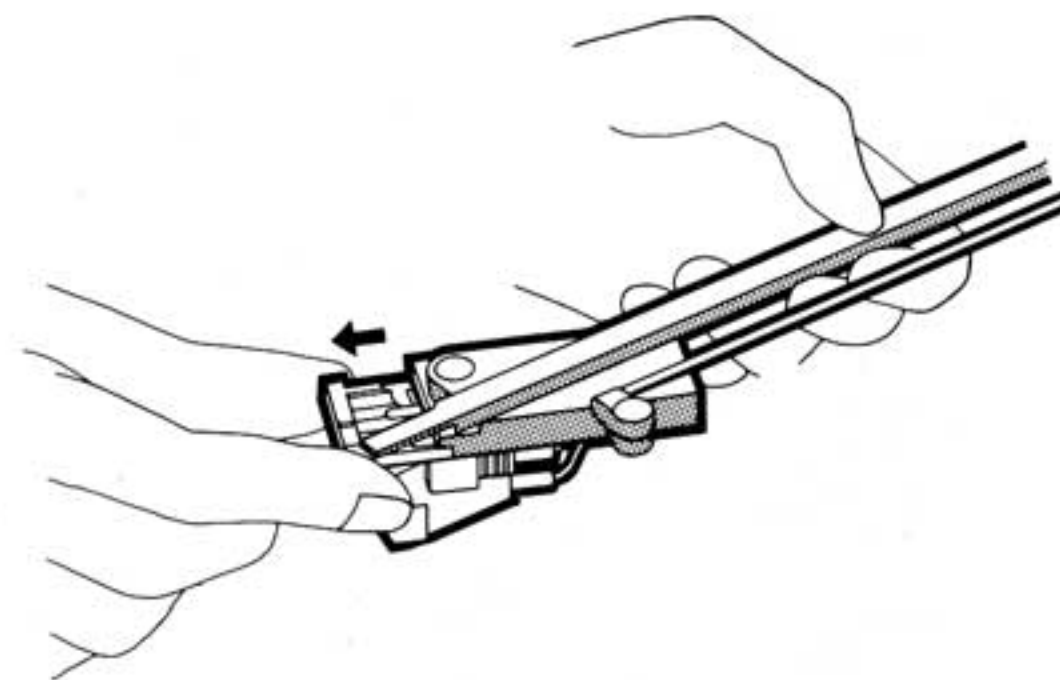

Removing the Carrier

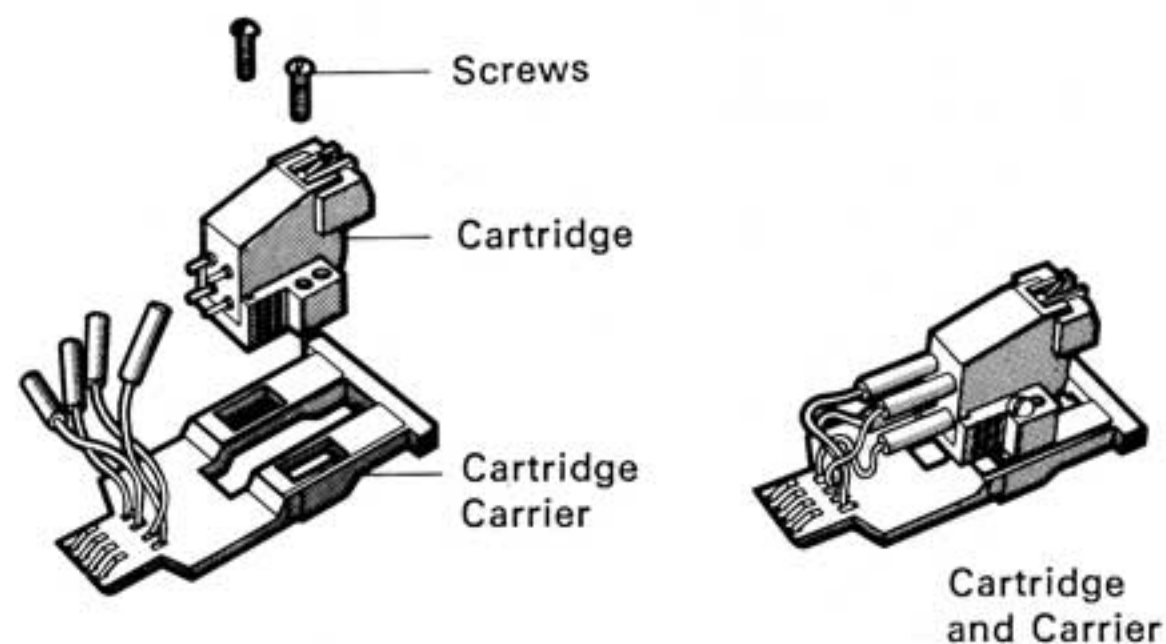

Assembling the Cartridge and Carrier

setting up

C To align the cartridge

Slide the carrier into the slots in the clear plastic setting gauge. Take care that the stylus does not catch on the gauge as the cartridge enters. The stylus tip must be vertically below the point at which the lines on the gauge cross. If not, move the cartridge until it is correctly aligned. When alignment is satisfactory, tighten both fixing screws and remove the gauge. Should the screws now project through the locking plate, fit a shorter pair.

D To connect the leads

Connect the insulated leads on the carrier by pushing their tags onto the cartridge terminal pins. Use the following colour code with the cartridge manufacturer's instructions.

- Red - Right channel signal
- Green - Right channel 'ground'
- White - Left channel signal
- Blue - Left channel 'ground'

If a cartridge has only three pins or tags, use the green lead, or green and blue leads joined together. Insulate and tuck away any lead not required.

E To refit the carrier

Move the pickup arm locking lever to 'Free'. Support the arm over the turntable away from the operating controls to avoid risk of damage to the cartridge.

Fit the contact end of the carrier into the guide slots under the rear of the head. The carrier should now be supported by the head and protrude approximately $\frac{1}{4}$ inch from the front of the head. Gently push the carrier in to the head. It does not matter whether the cartridge tilting lever is at M or A at this stage.

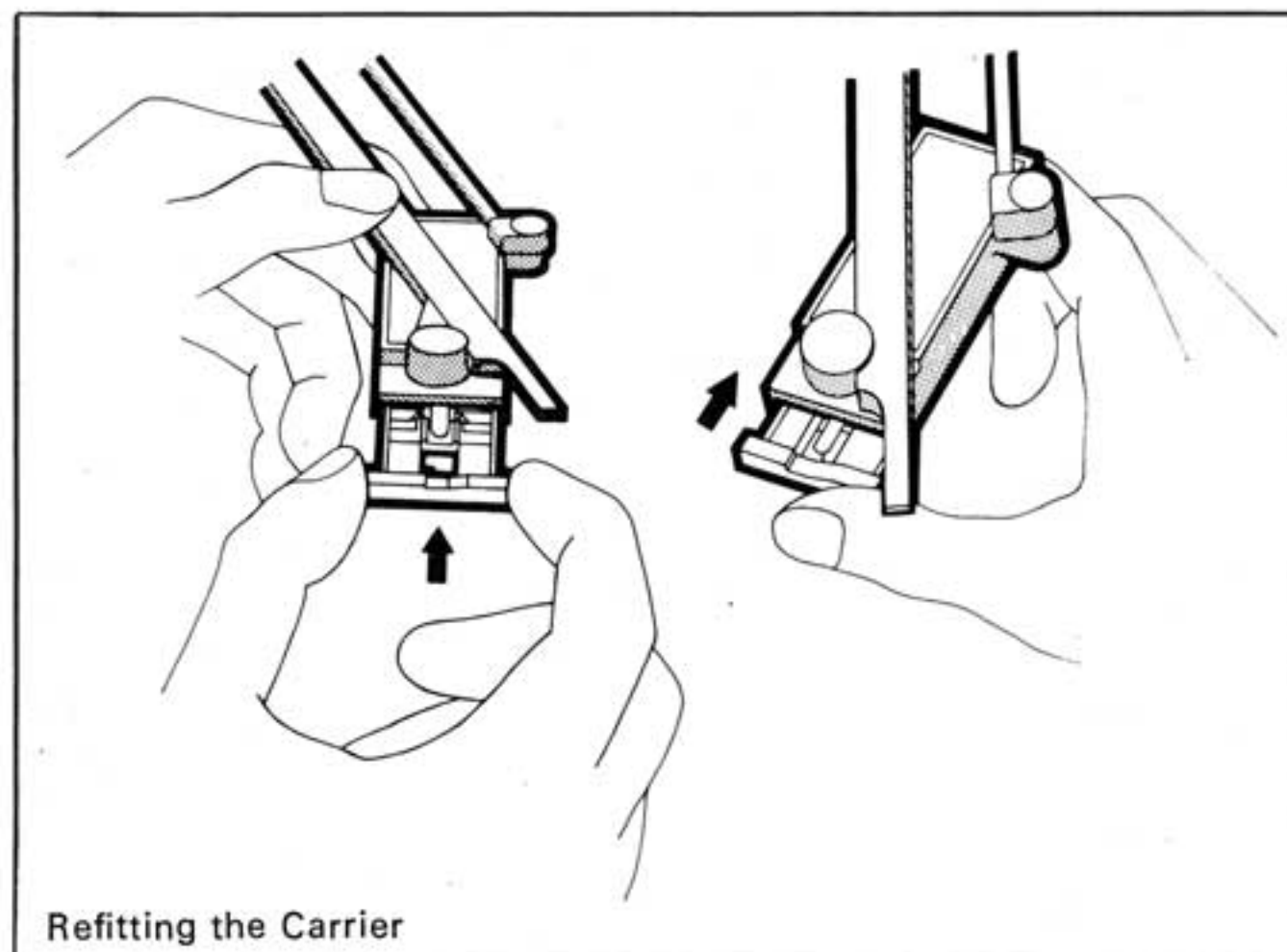
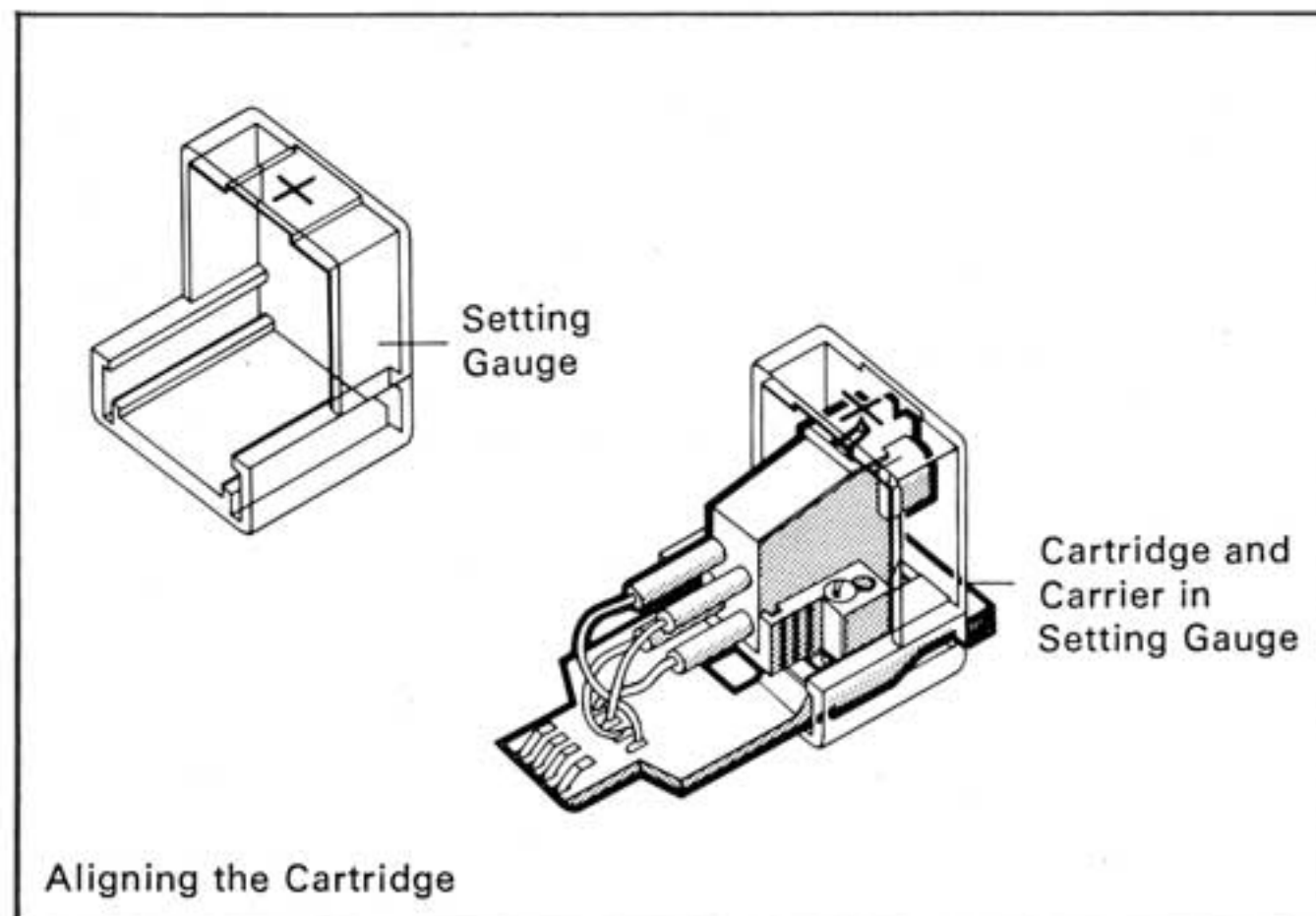

setting up

F To set stylus force

- 1 Slide the stylus force weight along the pickup arm until its red centre-line is level with the black line marked 0 on top of the arm.
- 2 With the pickup cartridge fitted remove or retract its stylus guard and turn the pickup arm locking lever to 'Free' so that the arm pivots sideways freely. Move the arm inwards, taking care to support it so that the stylus does not touch the turntable mat.
- 3 Wind the pickup arm counterbalance weight backwards or forwards until the arm balances with the stylus tip at the height of one record on the turntable.
- 4 Lock the pickup arm to its rest and set the stylus force recommended by the cartridge manufacturer by sliding the stylus force weight forwards. If a Shure M.93E cartridge is fitted, set 2 grams. If a Shure M.91ED or a Garrard GM50E or GM50NE cartridge is fitted set 1 - 1½ grams (Suffix E denotes an elliptical stylus tip). The setting is correct when the line on the weight is level with the line on top of the pickup arm corresponding to the required force. The scale is calibrated up to 3 grams in steps of 1/10th gram and the minimum recommended force is 1 gram.

G The pickup arm bias compensator

There is a natural tendency for almost any pickup arm to be drawn or biased inwards while playing a record. The bias compensator counteracts this by applying an equal force in the opposite direction, so minimising stereo image unbalance and premature wear of the stylus and record. The degree of bias is directly related to stylus force and the profile of the stylus tip, so that the compensator setting must allow for these factors.

In the Garrard system a sliding shield controls the repulsion between similar poles of two disc magnets - one on the moving pickup arm, the other on its static bearing surround. The reaction between these magnets imparts the required outward force on the pickup arm without mechanical linkage.

A bias compensator is also known as an anti-skating device and a side thrust compensator.

To set the bias compensator

- 1 For a cartridge with an elliptical stylus tip.
Slide the magnet shield along the pickup arm bearing surround until its red line is level with a point on the 'elliptical' scale corresponding to the stylus force.
If, say, 2 grams stylus force has been set, move the line to the figure 2 on this scale. It is calibrated 0-2½.

- 2 For a CD-4 cartridge or one with a spherical (conical) stylus tip.
Proceed as before but use the 'CD-4' scale, calibrated 0-3.

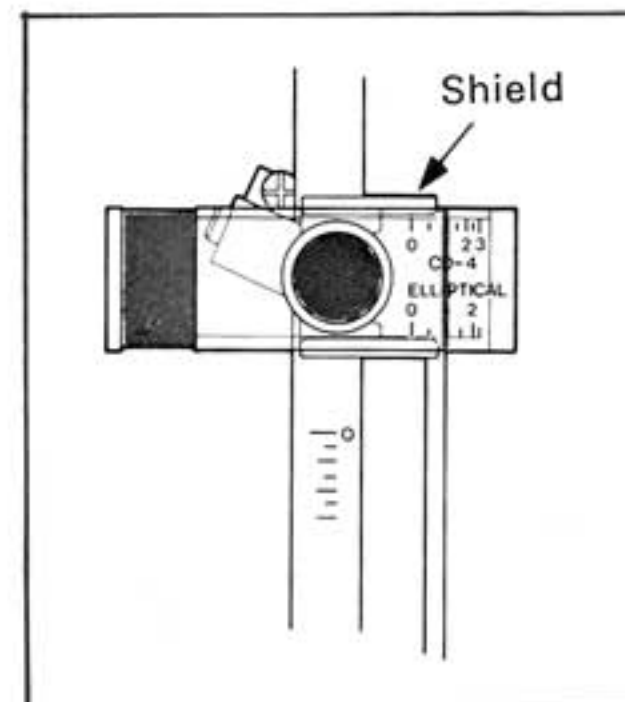
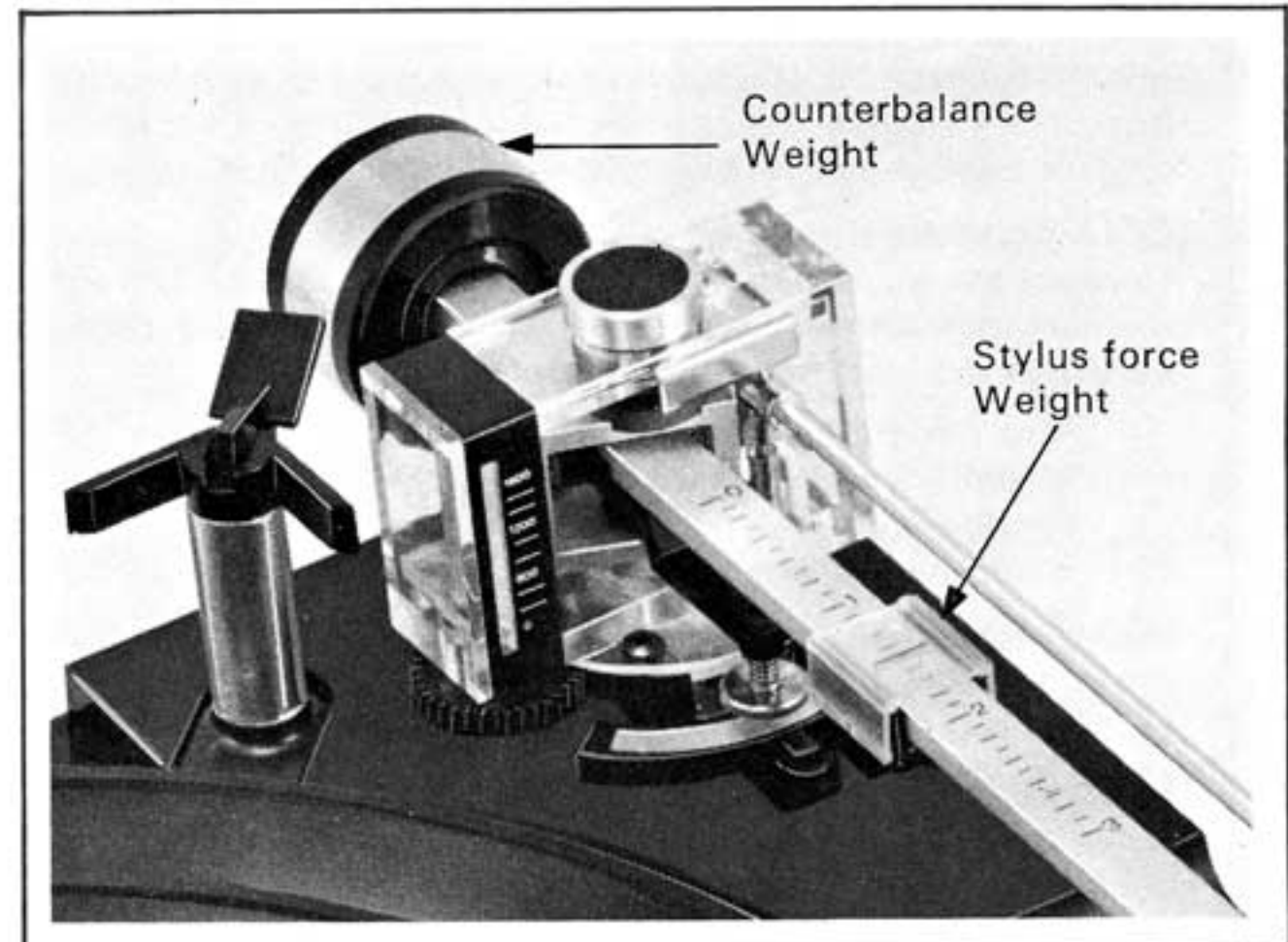

setting up

Audio

When audio (phono) connecting leads are already attached, simply plug their free ends in to the amplifier's 'phono' or 'pickup' input sockets. Use the 'magnetic' or 'ceramic' input depending on the type of pickup cartridge used. Garrard connecting leads are terminated in black (right channel) and grey (left channel) R.C.A.-type phono plugs or a 5-pin DIN plug, Type A, according to territory. These leads are suitable for use in CD-4 quadraphonic systems. If your amplifier does not have corresponding input sockets, obtain an alternative Garrard lead from your dealer. See page 17. Most U.S.A. and Canadian models also have a green signal ground lead terminated in a spade lug. Secure this lug to the grounding screw on the amplifier in accordance with the manufacturer's advice.

Power Supply

a *U.S.A. and Canadian Models (110/125V, 60Hz)* have flexible power supply cords terminated in a standard U.S.-type plug with 2 parallel blades. Connect this plug to a corresponding receptacle on the amplifier or wall.

U.S. Forces' Models (110/120, or 220/240V, 50 or 60Hz) may be supplied with flexible power supply cords terminated in a standard European-type plug with 2 round pins.

Important - these are dual voltage range models and, before connecting one to a power supply receptacle, the setting of the voltage selector switch must be correct. To check this, lift the mat and look through one of the openings in the turntable. The sliding switch should show the nominal voltage of the local power supply - either 115 or 230V.

If it does not, use a small screwdriver to slide the switch fully in the appropriate direction.

These models have 50Hz stroboscopic discs and motor pulleys fitted but are also provided with equivalent parts for conversion to 60Hz supplies.

b *United Kingdom Models (220/240V, 50Hz)*

1 *Important* - When a Garrard 3-core mains lead is attached, its wires are coloured in accordance with the following code: Green and Yellow - Earth, Blue - Neutral, Brown - Live. As the colours of the wires in the mains lead of this apparatus may not correspond to the colours marked identifying the terminals in your power supply plug, proceed as follows: The wire coloured green and yellow must be connected to the terminal in the plug marked by the letter E or by the safety earth symbol \perp or coloured green or green and yellow. The

wire coloured blue must be connected to the terminal in the plug marked by the letter N or coloured black. The wire coloured brown must be connected to the terminal in the plug marked by the letter L or coloured red.

If a 13 amp (BS 1363) plug is used a 3A fuse must be fitted. If any other type of plug is used a 5A fuse must be fitted either in the plug or adaptor or at the distributor board.

Warning: This apparatus must be earthed. When in doubt consult a qualified electrician.

2 When a Garrard 2-core mains lead is attached, its wires are coloured blue and brown. Connect them in the same way as the 3-core lead described in paragraph 1, disregarding the earth connection.

c *European Models (220/240V, 50Hz)*

1 When a flexible mains lead is provided with a standard European-type plug with 2 round pins, connect this to a corresponding socket-outlet on the amplifier or wall.

2 When a Garrard 2-core mains lead is attached, connect the wires to the power supply plug, in accordance with the plug manufacturers instructions.

Double insulated models are identified by a label in a prominent position. The label bears the phrase 'double insulated' or the \square symbol or both of them. These models do not require an earth lead, but any associated equipment must be earthed if its manufacturer specifies the need for this.

● Instructions for attaching leads to the deck will be found on page 12.

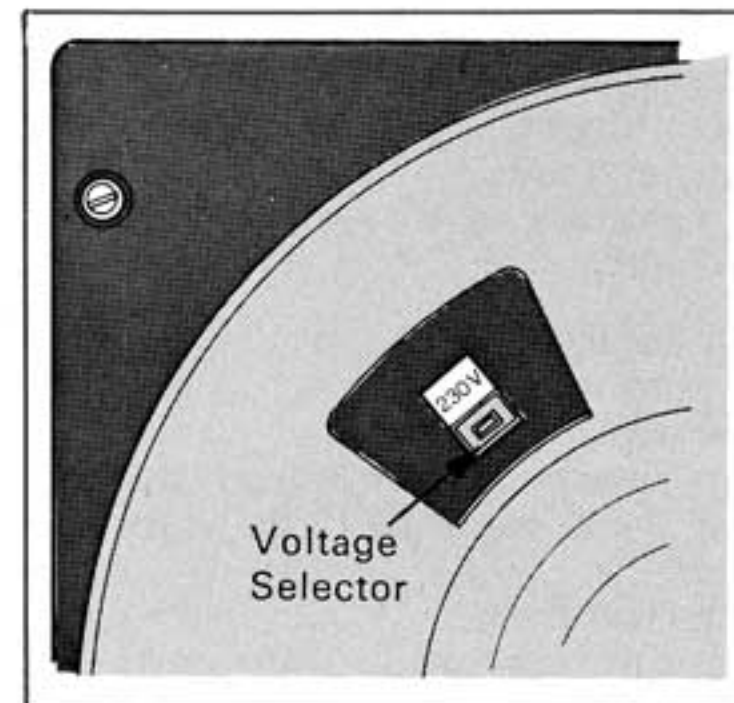

operation

Please open out page 10 while reading this section.

Before use

- 1 Both transit screws must be turned fully clockwise, so that the unit floats freely on its mounting springs.
- 2 The stylus guard must be removed or retracted from the pickup cartridge, according to type.
- 3 The locking lever on the pickup arm rest must point to 'Free'.
- 4 The pitch control should be at its mid-setting, with the single line halfway between + and - on the rotating ring.

To play a single record manually

- 1 Fit the short record spindle into the centre of the turntable. Rotate the spindle until it can be pressed down and is held lightly in place.
- 2 Place a record on the turntable, using the adaptor provided if the record has a centre hole of $1\frac{1}{2}$ inch diameter.
- 3 Turn the speed selector knob to indicate 33 or 45 rev/min as required, disregarding the reference to record size. Set the cartridge to the correct angle for playing a single record by moving its tilting lever to M.
- 4 Move the 'Manual' control fully to 'On' and release it.
- 5 a Place a finger under the lifting lever at the front of the pickup arm and lower it onto the record - or
b Move the 'Cue' control tab to 'Lift' position the pickup arm directly over the place at which play is to start, and steadily return the tab to 'Play'. Provision is made for particularly accurate location for such purposes as dubbing a record onto tape. To take advantage of this special facility, move the tab carefully towards 'Play' until the stylus is approximately $1/16$ th inch (1.5mm) above the record, then stop. Any final adjustment to the point of contact can be made before the tab is moved fully to 'Play'.

After playing a record the pickup arm will return to its rest and the unit switch off automatically.

To play a single record automatically

- 1 Fit the short record spindle and place the record on the turntable as for manual play.
- 2 Turn the speed and size selector knob to indicate the setting for the record to be played. For example 33 12 for a $33\frac{1}{2}$ rev/min 12 inch diameter record.
- 3 Set the cartridge tilting lever to M.
- 4 Move the 'Automatic' control tab fully to 'Start' and hold it there

for a moment while the mechanism engages, then release it. The record will then be played, the pickup arm returned to its rest and the unit switched off automatically.

To play a sequence of records automatically

- 1 Fit the long record spindle into the centre of the turntable. Rotate the spindle until it can be pressed down and is held in place.
- 2 a 12 inch records. Place up to six $33\frac{1}{2}$ rev/min (long-playing) records on the step of the record spindle with the edge of the lowest record resting on the support platform. Lift the record steady fully, then move it inwards and downwards so that it bears lightly on the top of the record stack to provide additional stability.
b 7 inch records with large centre holes. Fit the Garrard Type LRS100 large record spindle (available from your dealer as an optional extra) over the long record spindle and load up to six 7 inch records onto it in a level position.
c 7 inch records with small centre holes. Fit the Garrard Type A6 record platform adaptor. This is available from your dealer as an optional extra, complete with instructions for use.
- 3 Turn the speed and size selector knob to indicate the setting for the record to be played. For example 33 12 for $33\frac{1}{2}$ rev/min, 12 inch diameter record.
- 4 Set the cartridge to the appropriate angle for playing a sequence of records by moving its tilting lever to A.
- 5 Move the 'Automatic' control tab fully to 'Start' and hold it there for a moment while the mechanism engages, then release it. When all records have been played the pickup arm will return to its rest and the unit will switch off automatically.
- 6 Unload the records, after carefully lifting the record spindle straight up and clear.

operation

Additional facilities

Pause

Record play can be interrupted at any time by moving the 'Cue' control to 'Lift'. To resume play move the control back to 'Play'. Lifting and lowering is controlled by a damped action for gentle movement. The pause facility can be particularly useful for passing over a passage of music and interrupting play for a short time while, for example, answering the telephone.

Repeat

A single record being played automatically or the last record of a stack, can be replayed from the beginning. To do this, move the 'Automatic' control to 'Start' before the pickup arm lifts after playing the record.

Reject

Any record of a stack except the last can be rejected and the next record played by moving the 'Automatic' control to 'Start'.

Stop

To return the pickup arm to its rest and switch the unit off while playing a single record, or the last record of a stack, move the 'Automatic' control to 'Stop'.

Record pitch control

This has a range of $\pm 3\%$ at $33\frac{1}{3}$ rev/min ($\pm 2\frac{1}{2}\%$ at 45 rev/min) with two main objects:

- 1 to enable the speed of the turntable to be set accurately to $33\frac{1}{3}$ and 45 rev/min by means of its stroboscopic image
- 2 to enable a musician to make minor adjustments to the pitch of an individual recording. This will be set by ear to the listener's particular requirements by moving the outer control ring clockwise to raise pitch or counterclockwise to lower it.

To check turntable speed

- 1 Play a single record manually, as previously described. The row of bars corresponding to the speed selector setting will appear stationary in the stroboscope window when speed is accurate.
- 2 If the bars appear to drift clockwise then speed is slightly fast and the pitch control ring should be moved so that the — end of the scale approaches the central white line. The reverse also applies.

- Handle, store and clean records as their makers recommend. The turntable mat is designed to be cleaned easily with a soft brush. Periodic attention will help keep records in good condition.
- Make sure that there is always a record ready to be played before switching on.
- Keep the cartridge stylus clean and have it microscopically examined for signs of wear as recommended by its manufacturer. See 'Automatic Record Counter'.
- Carry out routine maintenance as described on page 14.

operation

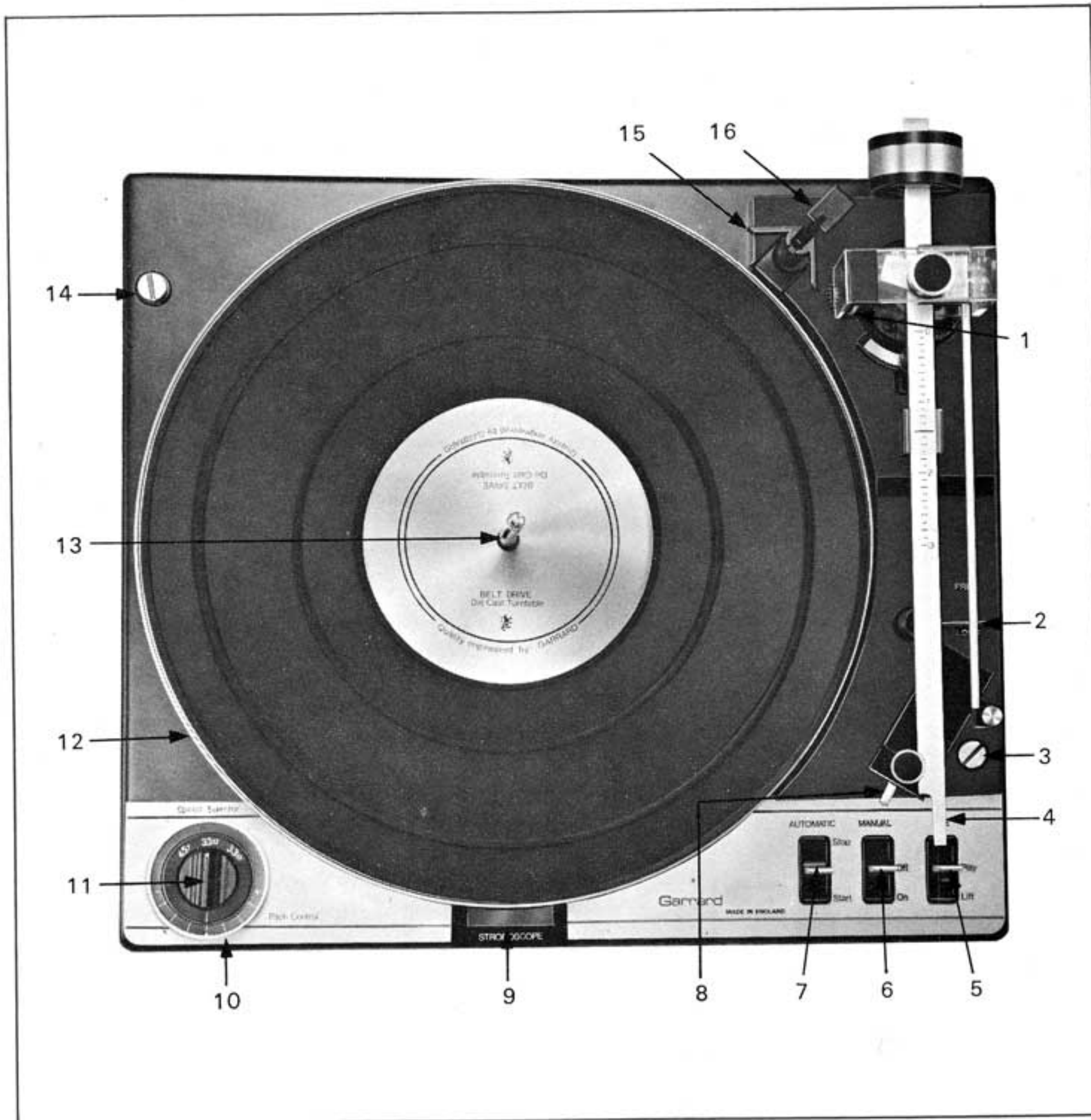

Key to diagram

- 1 Automatic record counter scale.
- 2 Pickup arm locking lever.
- 3 Transit screw (1 of 2).
- 4 Pickup arm finger lift.
- 5 Cue control.
- 6 Manual control.
- 7 Automatic control.
- 8 Cartridge tilting lever.
- 9 Stroboscope window.
- 10 Record pitch control.
- 11 Record speed (and size) selector.
- 12 Turntable.
- 13 Record spindle.
- 14 Transit screw (1 of 2).
- 15 Record support platform.
- 16 Record steady.

the record counter

The automatic record counter

This registers the number of record sides played and so enables the approximate stylus playing time to be calculated. It helps decide when the stylus tip should be microscopically examined for signs of wear as its maker recommends. After each side has been played, the red pointer moves fractionally up the scale calibrated from 0 to 1800 sides in steps of 200 sides.

Setting the counter to zero

This is set during manufacture and will only need to be reset when the pointer reaches the top of the scale and when a new stylus is fitted.

To set zero, support the pickup arm over the turntable and rotate the toothed ratchet wheel counter-clockwise until the pointer is half-way up the mark 0 at the lower end of the scale. Return the arm to its rest.

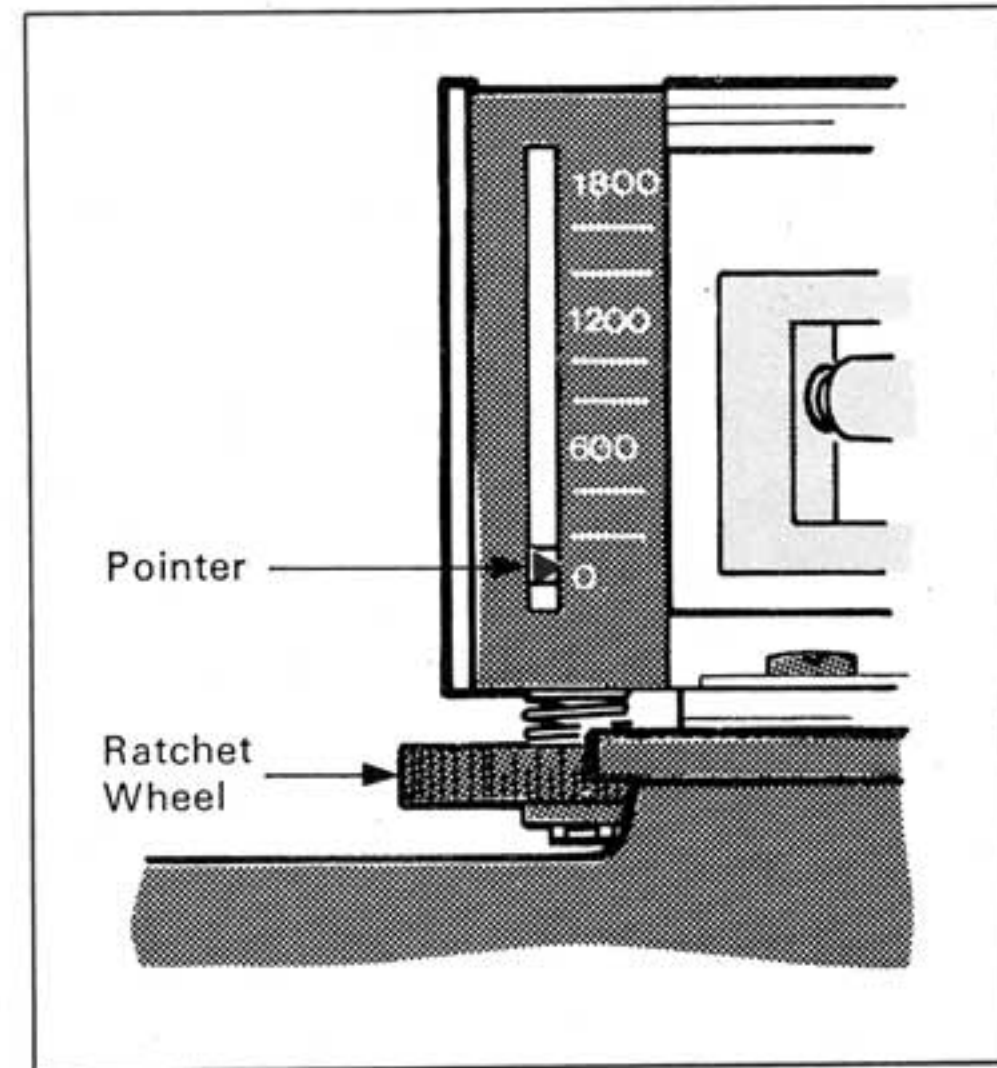

setting up

Audio

When audio (phono) connecting leads are not provided, obtain genuine Garrard leads from your dealer. Connect the black phono plug to the socket under the unit plate marked R (right channel) and the grey plug to the socket marked L (left channel). The other ends of the leads must be terminated to suit your amplifier's input arrangements and connected as described on page 7.

Power Supply Leads

To fit a 3-core mains lead, attach a plug to a convenient length of flexible cable of at least 3A rating as described on page 7. Connect the wires in this mains lead to the terminals in the block beneath the deck in the following way, green and yellow lead to the screw marked \perp , blue lead to the screw marked N and brown lead to the screw marked L.

To fit a 2-core mains lead, (only to double insulated and European Models) attach a plug to a convenient length of flexible cable of at least 3A rating.

Connect the wires in this lead to the terminals in the block beneath the deck in the following way - blue lead to the screw marked N, black (or brown) lead to screw marked L. Disregard the screw marked \perp .

Double insulated models are identified by a label in a prominent position. The label bears the phrase 'double insulated' or the \square symbol or both of them. It is not necessary to earth these models, but any associated equipment must be earthed if its manufacturer specifies the need for this.

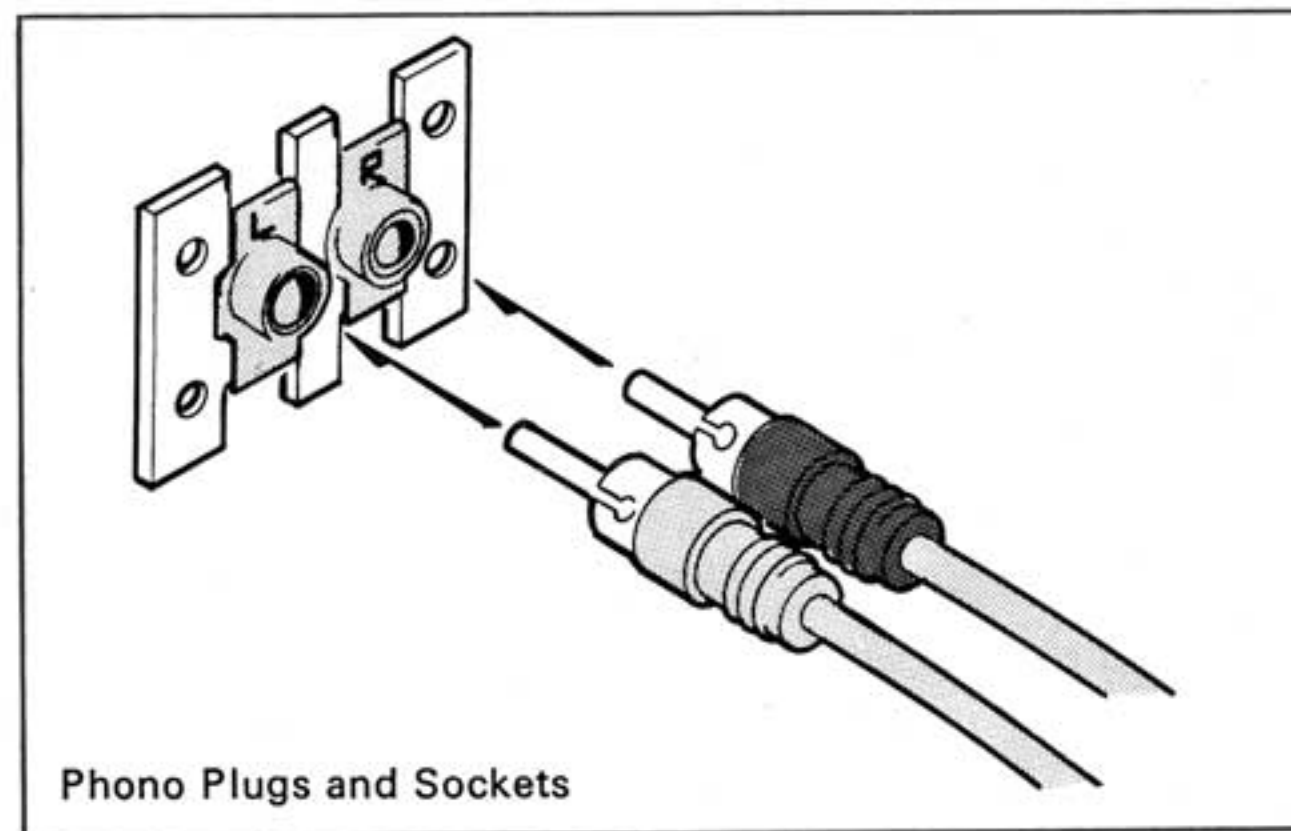

Phono Plugs and Sockets

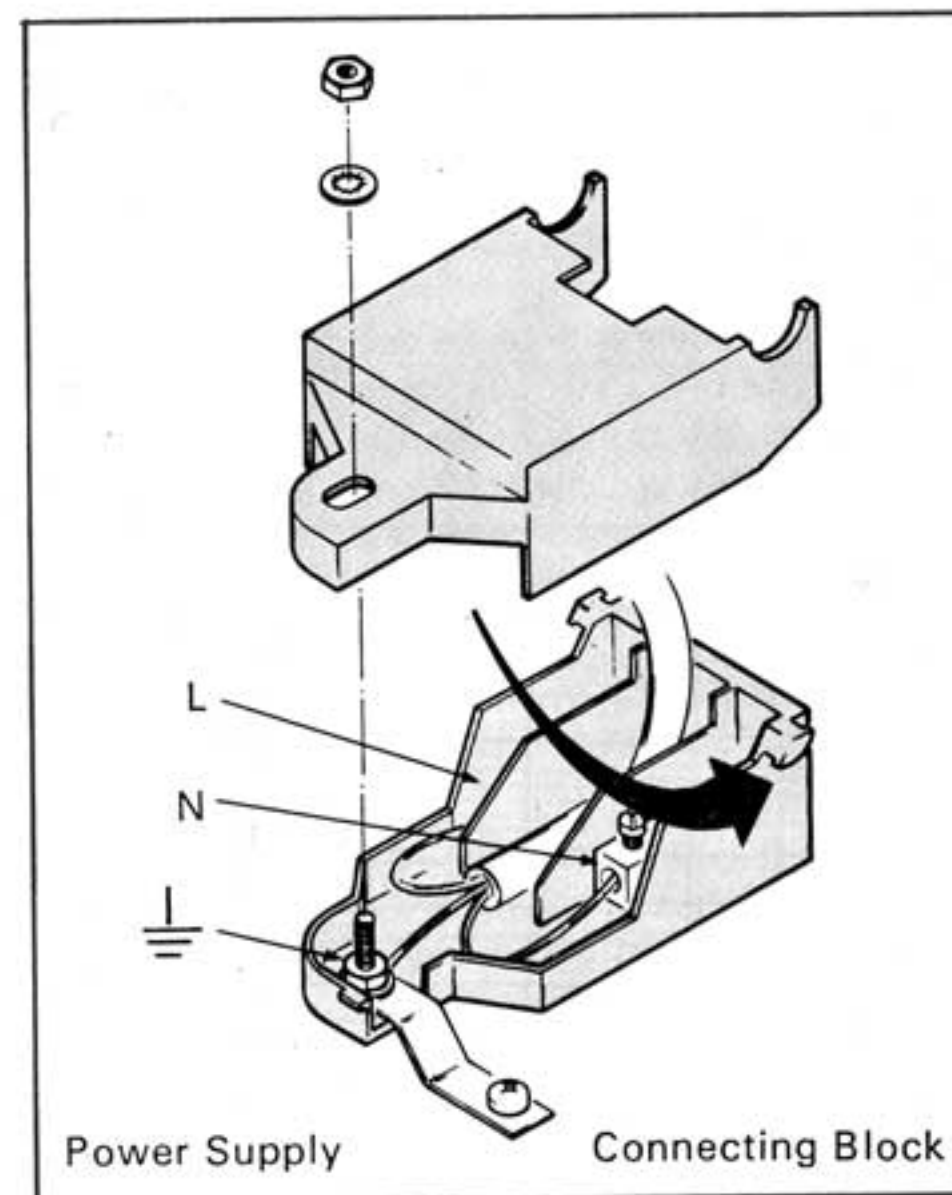

Power Supply

Connecting Block

setting up

The Garrard Type BHC 20 Base and Cover

The base (D on the diagram) is made of low-resonance material with a distinctive trim. A clamp (E) is provided to anchor the connecting leads, and a channel (C) along the back edge can be used to store a record spindle.

The cover (A) is a tinted moulding with adjustable friction-loaded hinges (B) (patents applied for) to hold it open at any practical angle. It can be lifted off or lowered while a stack of records is played.

To assemble the deck to the base

- 1 Unpack the deck, base and cover. Place the deck near the base, uncoil the connecting leads or attach leads if necessary. Pass them in through the top of the base and out through the large hole at the back.
 - 2 Turn both transit screws on the deck fully clockwise and their spring clips vertical.
 - 3 Assemble the deck to the base making sure that its four mounting springs engage their recesses (G) in the top of the base. Pull the connecting leads gently to make certain that they are clear of the mechanism.
 - 4 Press the deck down on its springs, then reach up from underneath the base and turn both transit clips horizontal to lock the deck to the base. This is most important.
 - 5 Unpack the transparent lead clamp moulding with its three fixing screws (F). Support the assembly on its front edge at about this angle \angle and slide the lead clamp into the back of the base as shown in the diagram. Guide the phono lead(s) through the slot in the clamp nearest the pickup arm. Pass the power supply lead through one of the other slots which holds it securely without excessive pinching. If a single earth or ground lead is provided pass this through the remaining slot. Fix the clamp with its three screws and pull the leads gently to check that they are held firmly. Look into the base through the clear panel. The leads should be slack enough to allow the deck to float freely on its mounting springs.
 - 6 Fit the turntable and mat. When the deck is connected and set up ready for use, the cover can be assembled by locating both its hinges in the slots at the back of the base.
- Since hinge friction reduces as the cover is lowered, do not let it fall.
 - Keep the cover closed when the equipment is not in use.
 - Place the module on a firm, level support with sufficient clearance

for adequate ventilation.

- Do not rest it on a speaker enclosure or too close to any other piece of equipment with a powerful mains transformer. This will minimise the risk of acoustic feedback and induced hum.
- Power supply and audio connections are described on page 7.

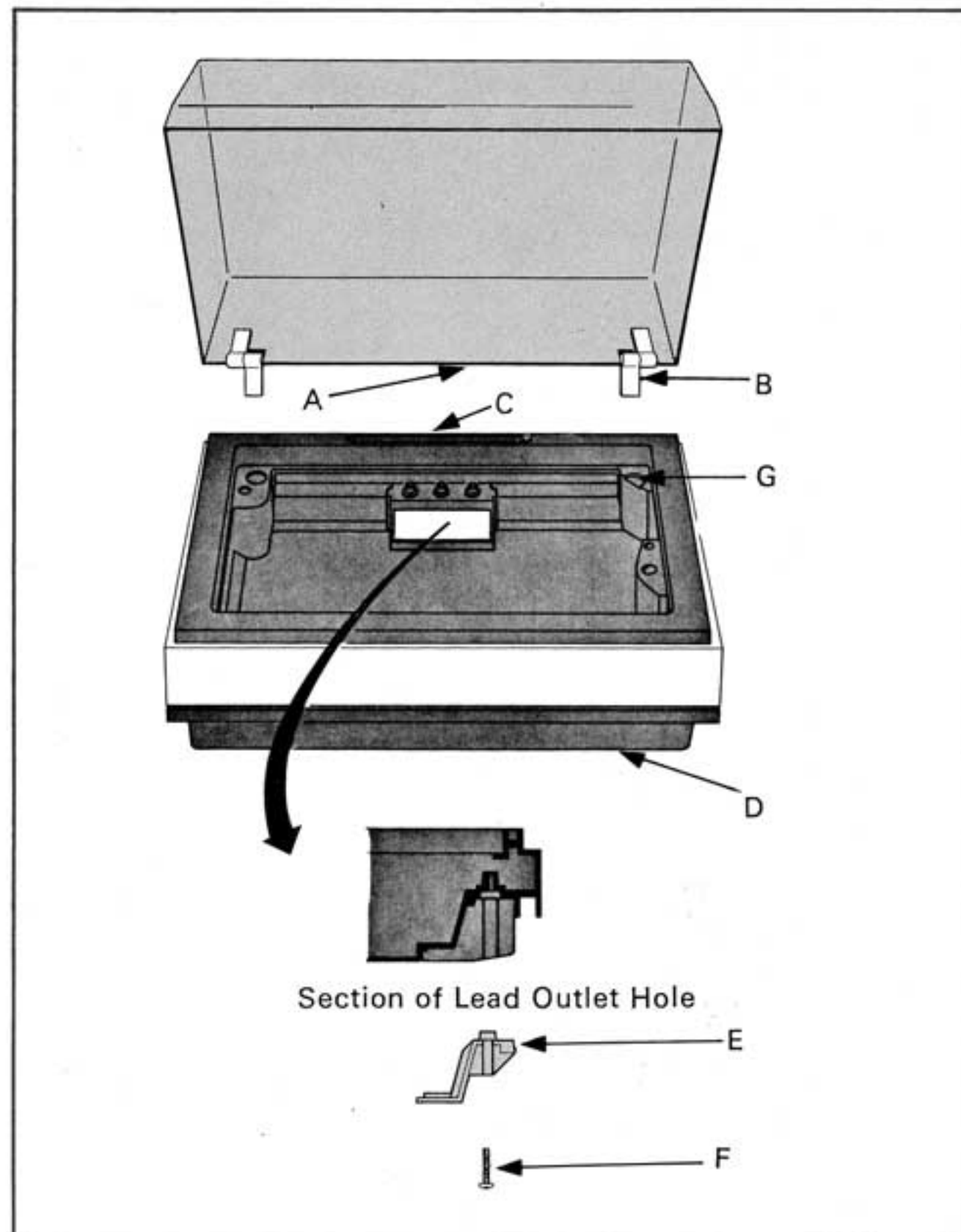

routine maintenance

Whilst careful design has reduced the need for maintenance to a minimum, periodic attention to the following simple points will prolong trouble-free listening.

The pickup cartridge stylus

If the stylus tip collects an accumulation of dust, sound quality will suffer. To clean it, unplug the stylus assembly if the cartridge design allows or withdraw the cartridge carrier from the front of the pickup arm and blow the dust off. Alternatively, stroke the dust away with an artist's camel-hair brush, working from the back of the stylus towards the front to avoid bending it. Do not use a solvent without the cartridge manufacturer's advice.

The stylus must be examined under a microscope periodically by your dealer or the cartridge manufacturer for the first signs of wear. A worn or chipped stylus damages records permanently.

The turntable mat

Clean this with a soft brush when necessary.

The drive system

Remove the turntable as described later, and apply a drop of high quality sewing machine oil to the bearings of the intermediate wheel, motor and turntable. Also smear the turntable spindle if the need becomes apparent. Oil on the driving surfaces of the motor pulley, intermediate wheel, drive belt or turntable will cause slippage. Periodically rub these surfaces with a clean, lint-free cloth to remove deposits and restore grip.

Lubrication points are marked A, B, C and D on the diagram alongside.

To remove the turntable

Lock the pickup arm to its rest, withdraw the record spindle and lift off the rubber mat complete with its centre disc. Note the position of the wire retaining clip for reassembly, then slide it off with a small screwdriver. Lift the turntable from diametrically opposite points on its rim.

To refit the turntable

Reassemble in the reverse order, noting the instructions in paragraphs 7, 8 and 9 on page 3.

A circular rib under the mat fits inside a similar rib on the turntable. The disc is secured by three rubber lugs around its recess in the mat. Put slight pressure on the disc after assembly to make sure that it lies flat.

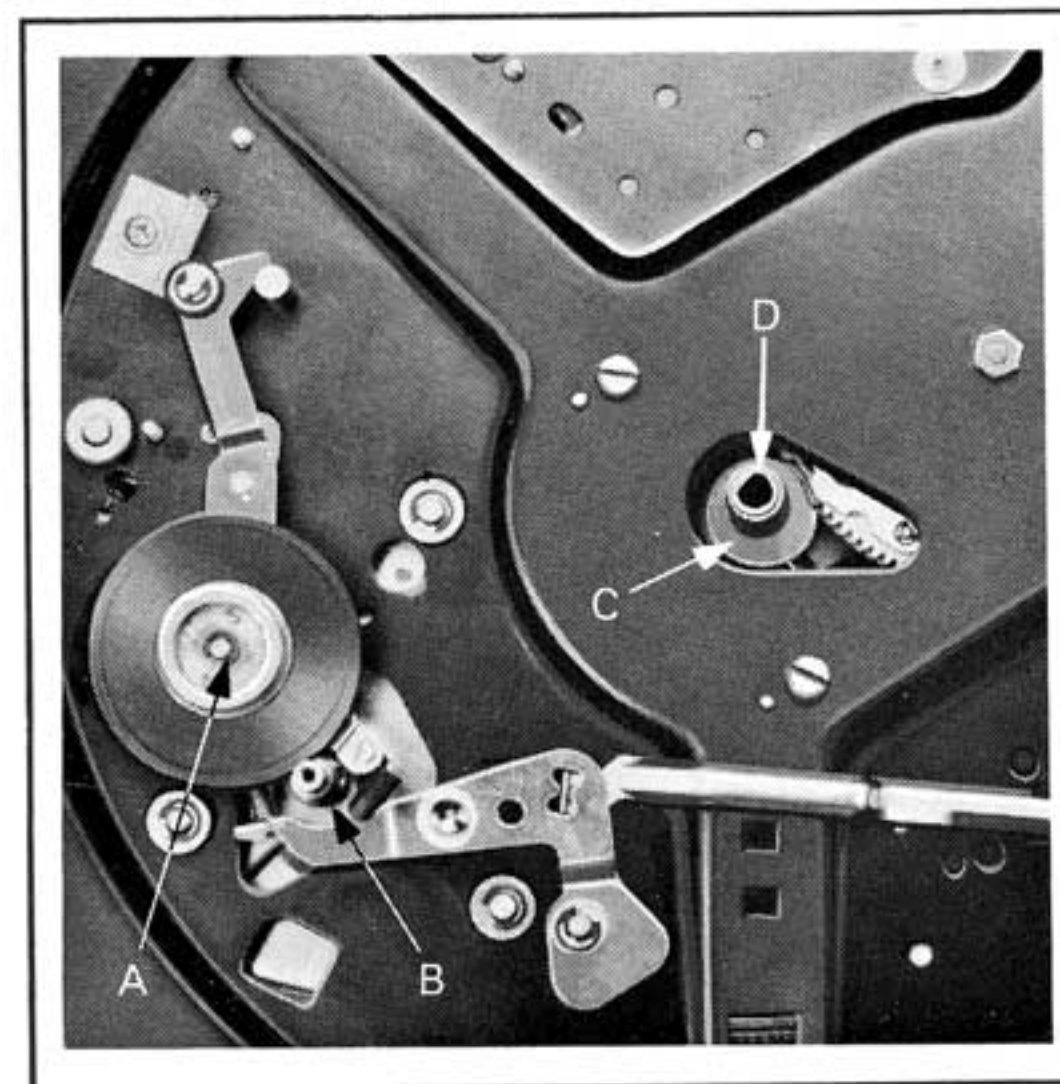
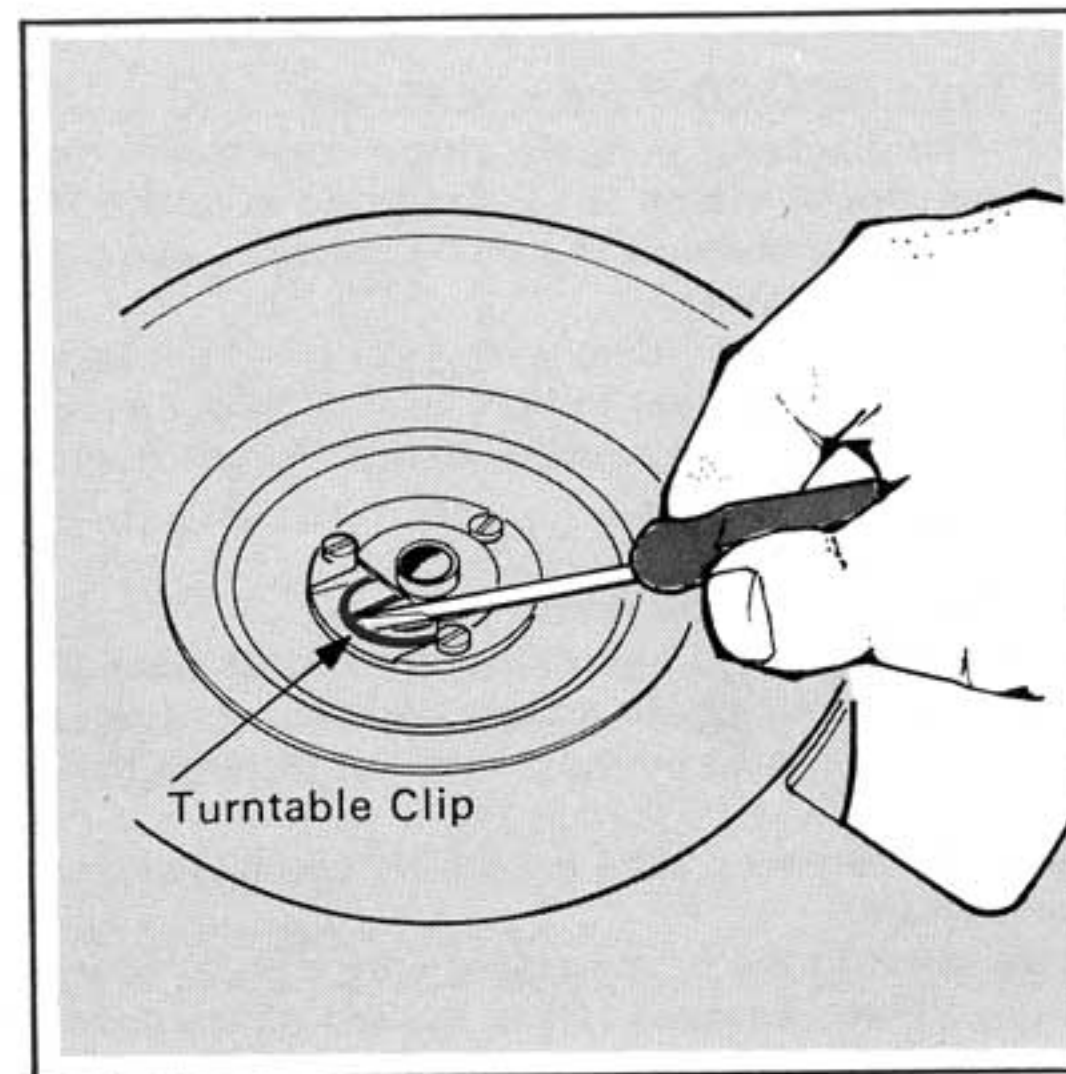

adjustments

Pickup arm lifting height

This is set during assembly and will not need to be reset unless an exceptionally deep or shallow pickup cartridge is fitted later. The pickup arm should rise sufficiently to return to its rest, without touching the underside of a record on the step of automatic record spindle.

The height to which the arm lifts automatically is controlled by screw A and further free movement of the arm is limited by screw C.

To adjust lifting height:

- 1 Turn restriction screw C clockwise a few turns to disengage it.
- 2 Turn screw A clockwise to raise the arm or counterclockwise to lower the lifting height.
- 3 After playing a record, switch off when the arm is about halfway back to its rest to check the setting. Finally, turn screw C counterclockwise until there is about 1/16th inch (1.5mm) free upward movement at the front of the arm.

Pickup lowering position

The point at which the stylus is lowered onto the record during automatic play is accurately set during assembly and will not normally need further adjustment. The stylus should land just inside the raised rim of the groove guard on a 12 inch record made to international standards. Adjusting screw B is visible when the pickup arm is locked to its rest. Insert a small screwdriver into the hole and turn the screw clockwise to move the arm inwards and counterclockwise to move it outwards.

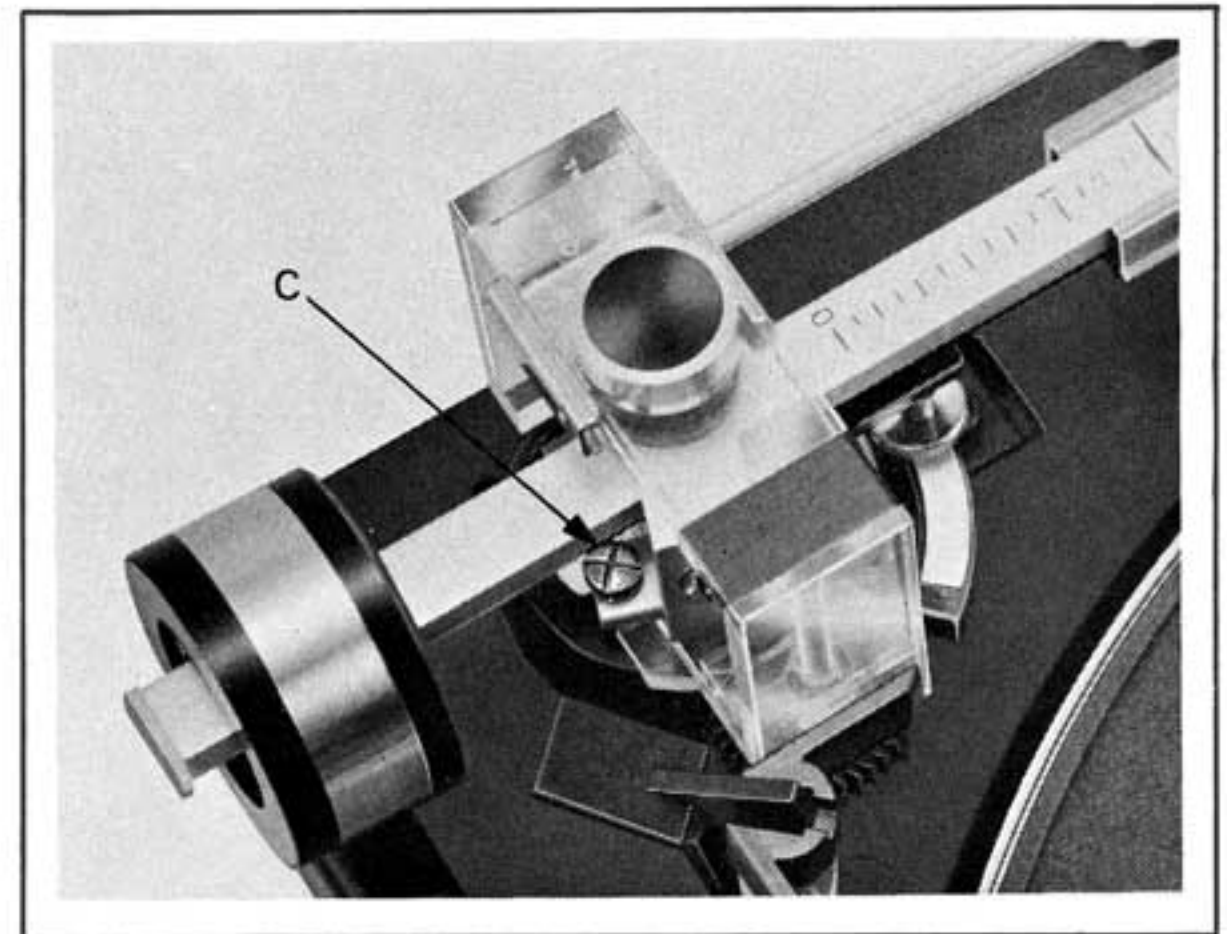
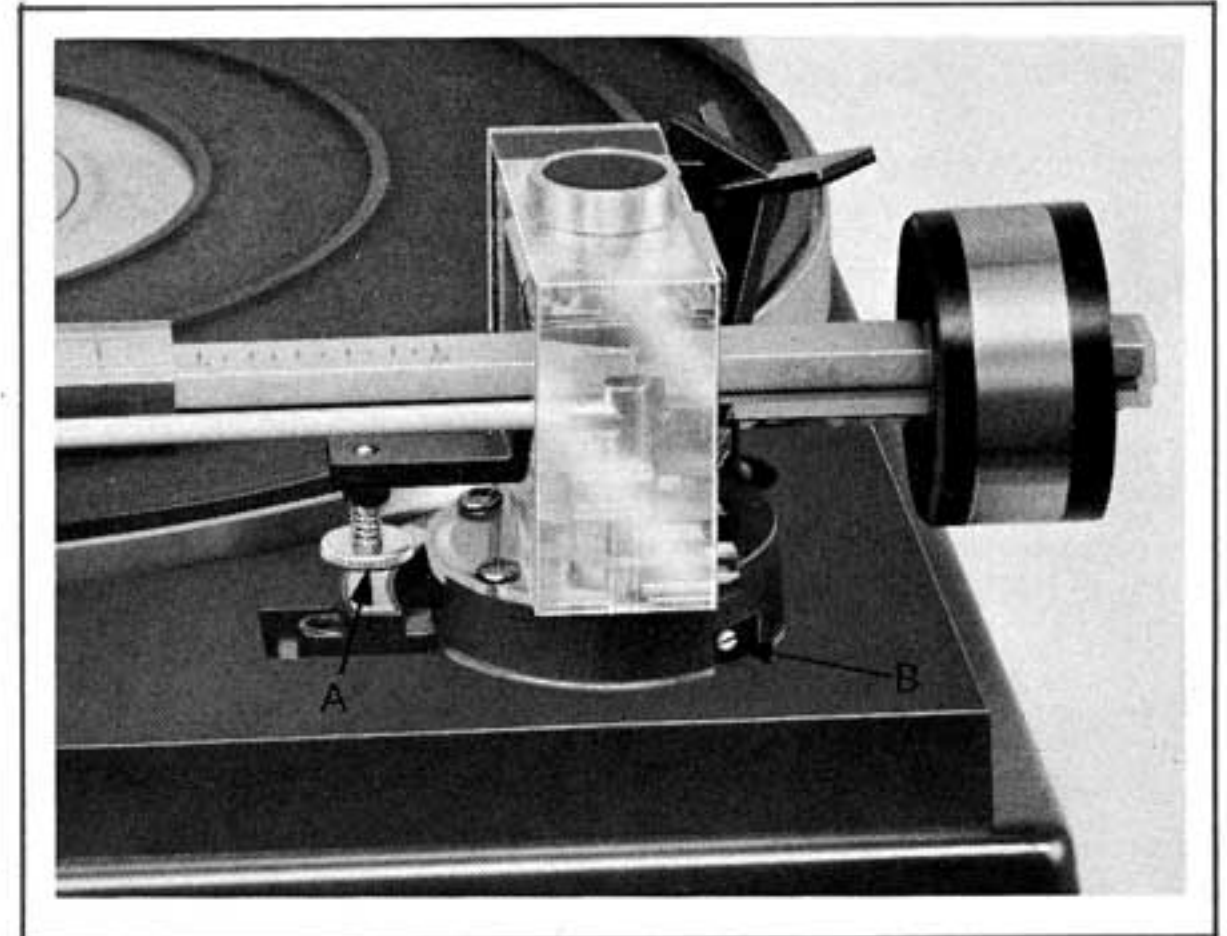

service hints

For safety, disconnect the unit from the power supply and protect the stylus whenever possible before investigating causes of problems.

Symptom	Probable cause	Remedy	See page
Turntable fails to start	No power supply to motor	Check power, leads and connections	7, 12
	Drive belt broken or displaced	Fit new belt or refit belt	3
Record pitch high or low	Incorrect motor pulley	A 50Hz pulley has a 1/32nd inch (1mm) square step at its base. A 60Hz pulley has not.	
	Pitch control setting	Reset, using stroboscope	9
	Incorrect voltage setting (dual range models)	Check changeover switch	7
Speed variation (Wow or flutter)	Warped record in a stack	Play it singly	
	Lubricant on driving surfaces	Clean with a lint-free cloth	
	Drive system needs lubrication	See 'Routine Maintenance'	14
Distorted reproduction	Worn or damaged stylus	Fit new stylus. Check stylus force	6
	Dust on records or stylus	Clean records as recommended by makers. See 'Routine Maintenance'	14
	Cartridge body touches record	Fit cartridge tilt wedge, deep edge forward	
Little or no sound	Faulty audio connections	Check leads and plugs	7
	Faulty pickup cartridge	Consult dealer	
Low pitched noise	Ground lead disconnected	Check connections. Consult dealer	
	Drive system needs lubrication	See 'Routine Maintenance'. Consult dealer	14
Pickup arm will not lower	Stylus force too low	Reset	15
	Lifting height or restrictor out of adjustment	Reset	15
	'Cue' control is at 'Lift'	Move tab to 'Play'	
	Arm locked to its rest	Move lever to 'Free'	

service and spares

Identification

Each version of this model is identified by an 8-figure number printed on a coloured paper label under the unit plate or on the packing carton. Please quote this number in any correspondence. Without it, 'Zero 2000B' must be specified and (when appropriate) the part number (if listed below), the pickup cartridge, power supply voltage and frequency, and the motor identification number from its bottom bearing cover. If the unit is sent for servicing, remove the turntable and pack it separately to avoid damage. It is not always essential to send the turntable - use your discretion. Kindly address enquiries to your dealer or, in case of difficulty, to Garrard Sales Service Department, Kembrey Street, Swindon, Wiltshire, SN2 6BP. Telephone Swindon 693471 (STD code 0793). In U.S.A. please contact - Plessey Consumer Products, Garrard Dealer Sales Division, 100 Commercial Street, Plainview, New York 11803.

SELECTED SPARE PARTS LIST

Description of part	Part No.
Automatic record spindle	77504
Single record spindle	75759
Large hole record adaptor	72698
Cartridge carrier, Type C3A*	75763/003
Cartridge setting gauge	75291
Turntable mat	77144
Centre disc for mat	77147
Stroboscope band (50Hz)	77892/002
Stroboscope band (60Hz)	77892/001
Turntable retaining clip	43857
Drive belt	77080
Intermediate wheel	77107
Motor pulley (50Hz)†	61254
Motor pulley (60Hz)†	61253

* With fixing screws

† With extractor and fitting instructions

Optional extras

- a mounting base and dust cover, Type BHC 20
- audio connecting leads, 2 phono plugs - 2 phono plugs (Part No. 78582) and 5-pin DIN plug - 2 phono plugs (Part No. 78588)
- power supply connecting leads
- a record spindle adaptor, Type LRS100, to play up to six records with 1½ inch (38mm) centre holes automatically
- a record platform adaptor, Type A6, to play up to six 7 inch records with small centre holes automatically

Equivalent parts may be supplied by overseas distributors.

